



# FLORIDA SKIP

VOL. 10 NO. 6

The All Florida Radio Amateur's Publication

NOVEMBER 1966

Price 20¢

## My Visit To The W4QSL Bureau

BY LARRY LOPER, W4WHF

Having received DX cards thru the bureau from time to time and being interested in DX and having not received any cards for about 8 months and about to go on vacation, I decided to spend at least one night in Chattanooga, Tennessee and try to visit the QSL Bureau and pick up what cards I might have in there, and also to try to bring back to Sarasota, as many cards as I could for the DX'ers here.

The XYL and I first went up to North Carolina mountains for the cool air and beautiful scenery. After having enjoyed ourselves for a few days we headed down out of the mountains for Chattanooga and warm weather again.

We arrived in Chattanooga about 4 pm, got settled in a motel and I called the Chamber of Commerce to find out where the bureau is located. They did not know but referred me to the Frey Institute. I called it and found out that it was located in the heart of the city. I went down and met Mr. Francis Bishop, who greeted me cordially and told me who to call, and let me use his phone.

I contacted Mr. Charlie Well-er, Jr., a very active ham who told me that the bureau was not normally open on Wednesday, but for me to call back at 7:30 pm and he would know if it would be open and if it was not he would come down and let me in anyway.

Shortly after 7:30 pm I met Charlie in front of the Frey

Institute and followed him over to the bureau about four blocks away from the institute. He showed me thru the bureau. I never saw so many QSL cards in all my life.

The following is an account of the bureau as I saw it: The bureau receives about 10,000 cards a week, and after the last DX contest received about 50,000 cards. The first thing after a batch of cards comes in is to separate them into three main piles of K4's, W4's and WA and WB4's. The K4's are then taken to the K4 pigeon holes where they are sorted out alphabetically according to the first letter after the 4, for example, K4A's K4B's K4C's etc. Of course the W4 and the WA and WB4 cards are taken to their respective places, and filed. From these locations the cards are moved to a large table where they are stacked ready to separate out the cards going to one station. When these

(Continued on Page 16)

## Confidential

We are aware of a certain job opening which can be filled immediately. Man must be experienced Ham, able to deal with the public and other hams. Age no consideration. Main requirement is responsibility to job which can easily lead to greater rewards as worth is proven. Miami area. - Write Florida SKIP, P. O. Box 501 Miami Springs, Fla. 33166



Here Don Layman K4QAY explains to Joe Engressia WA4JZT (sightless) of South Miami the operation of the "Argus tuner". For details read story by Jim Wilson below.

(Photo by W4IEH)

## BROWARD AMATEUR RADIO CLUB

# "Project Argus"

Several years ago there was an article in QST describing a piece of electronic gear which held great promise for our less fortunate ham friends without sight.

This piece of gear, called a Tone Comparator, when properly hooked up to a transmitter enabled the blind ham to tune the transmitter by comparing a variable tone with a calibrated reference tone. Thus he could identify the meter readings in all functions of the meter - plate current, grid current, plate voltage or bias. Its prospects were wonderful.

Two people in South Florida were greatly impressed by the article for different reasons. In Miami Joe Engressia, Sr. told himself this was "just the ticket" for Joe, Jr. WA4-JZT, who had been blind since childhood and had great difficulty tuning a transmitter. A considerable sum was spent for parts and several "experts" worked on it. Suffice it to say the unit never materialized so Joe, Jr. struggled along without it.

While all this was going on, Don Layman K4QAY of Hollywood,

(Continued on Page 11)

## FLORIDA SKIP, INC.

P.O. Box 501  
Miami Springs, Florida 33166

Enclosed is \$2.00 for 1 year or \$5.00 for 3 years.

for my membership to Florida Skip.

New  Renewal

My CORRECT address is:

Name \_\_\_\_\_ Call \_\_\_\_\_

Address \_\_\_\_\_

City \_\_\_\_\_

& State \_\_\_\_\_ Zip \_\_\_\_\_



EDITOR - Andy Clark, W4IYT  
P. O. Box 501 - Miami Springs, Fla. 33166  
"Member Amateur Radio News Serv."  
ADVERTISING MGR. - Frank Orcutt, W4JO  
Miami, Fla. Ph. 444-0481  
SPECIAL ASSISTANT  
WANTED

Second class postage paid at Miami, Fla. Published monthly.

The publishers of this paper do not assume responsibility of statements made by their advertisers in business competition. All signed articles published in this paper represent solely the individual opinions of the writer and not those of FLORIDA SKIP.

Deadline - 10th of month in Box 501, Miami Springs, Fla. 33166.

PERMISSION: Anything in Florida Skip may be reprinted in any other amateur radio publication in the world with a Credit Line please.

Dear Mabel XYL Award, c/o Skip, Box 501, Miami Springs, Fla.

### FLORIDA SKIP CORRESPONDENTS

IT'S A FACT. Geo. Hunt, W4NUT  
1218 S.W. 21st Ct., Ft. Lauderdale.

"Special OT reporter, Lee R. Scaggliozzi, W4VLN, 1226½ -  
15th St. N., St. Petersburg, Fla.  
33705."

HINTS & KINKS. R. V. Frederick  
K4UGC, 460 N. W. 108th Terrace,  
Miami 33150.

ONYX, MABEL, THE OLD TIMER  
c/o Florida Skip, P. O. Box 501,  
Miami Springs 33166.

160 M. Dave Hayden, W4WHK, 630  
River Road, Orange Park, Fla.

VHF - Bertha Eggert, WA4BMC,  
1510 - 17th Ave., No., Lake Worth.

Amateur TV. Robert Montgomery  
K4VFV, 903 Fernhill Rd., Orlan-  
do, Fla. 32808

ARMY MARS, W. E. Rabenhorst  
AD4VWY, 1715 - 29th Ave., Vero  
Beach, Fla. 32960

FSBA. W. G. Blasingame WA4-  
NEY, 716 Magnolia St., Neptune  
Beach, Fla. 32050

### NETS

FATT, Bob Street W4IET, 116  
Iroquois St., Miami Springs 33166.

2 FLORIDA SKIP, November 1966

FMTN, Clyde Mashburn, W4SDR  
25 So. Halifax, Daytona Beach.

### FLORIDA ARRL OFFICIALS

SCM-EASTERN FLA. Albert  
Hamel, K4SJH, 220 N. E. 25th St.,  
Pompano Beach, Fla.

SCM-WEST FLORIDA. Frank M.  
Butler, Jr., W4RKH, 494 Elliot Rd.  
Ft. Walton Beach, Fla.

SEC-EASTERN SEC. Andy Clark,  
W4IYT, 41 Lenape Dr., Miami  
Springs 33166.

SEC-WESTERN SEC. George  
Thurston, W4MLE, 2116 Gibbs Dr.,  
Tallahassee.

### CLUBS

BARC/NAVY MARS, Jim Wilson,  
W4GDK, 1204 Avacado Isle, Ft.  
Lauderdale, 33315.

NFARS, Jesse Morris, W4MVB,  
Box 1241, Jacksonville Beach,  
Fla. 32050

FLORIDORAS, Cathy Soehl,  
W4BAV, 647 Jungle Way, Sarasota  
33580.

Ft. Myers ARC, Ken Stewart,  
W4SMK, 2267 Maple Ave., Ft.  
Myers 33901.

Gainesville ARS, Bill Wells,  
K4RDP, 506 N. W. 19th Ave.,  
Gainesville 32601.

Orlando, ARC, Hal Shea, W4BKC  
736 Alfred Dr., Orlando 32810.

Platinum Coast ARS, Gene Starr  
WA4JDB, 856 Clarke Ave., Eau  
Gallie, Fla.

So. Miami, Charles K. Lingo WA4-  
RSX, P.O. Box 81, So. Miami.

Tampa HARC, Bill Lynn, K4VAO,  
Rte. 1, Box 243, Odessa, Fla.  
33556

Tampa, TARC, Dan Fisher,  
WA4CJG, 4622 Beach Park Dr.,  
Tampa, Fla. 33609.

## GUEST EDITORIAL

# Where Are We Headed?

Where are WE headed? First who is WE? If your the latter guy with the store bought rig and 24 hours of preparation you are in for a big disappointment. You may call yourself a "Ham Operator" but in reality you are a "Commercial Amateur Operator" or even a "Hobby Talker". Your investment in this game is only money and you cease to be an "Amateur". Even the dealers and manufacturers are a little leery of you after they take your money because they know you are not inoculated with blood and sweat and can not be depended upon to carry the ball. You fellows come and go. But first you clutter up the band and there is generally enough of you in the process of coming and going to make it miserable for the "dyed-in-the-wool Ham".

For the past two years the manufacturers have not been able to keep up with the demands for new equipment and as a result the dealers are back ordered many months behind schedule. Dealers today will tell you that only a maniac would go into the Ham Radio Merchandising Business. Will it get better? If it does you can bet a million dollars it will be SSB 100%. This means no one wants the old existing AM junk; try to trade some in and find out! Now I go for SSB I was double side band more than 10 years ago, went kit SSB over three years ago. I'm not condemning SSB as such. If all hams were gentlemen and operated their SSB with respect on the ham bands, knowing that they might clobber the AM boy, there would be no complaints. The general SSB opinion of AM is that it is ancient and no longer even belongs on the air. This is a rather "commercial" attitude for an amateur hobby. This attitude carried to excess will eventually catch up with our SSB operating techniques and most assuredly in the not too distant future, it will be dog eat dog and don't you forget it!

Vero Beach, Dennis Yantiz WA4YFY  
P. O. Box 44, Vero Beach, Fla.  
32960.

W. FLORIDA NEWS, Frank Butler,  
Jr., W4RKH, 404 E. Elliot Rd.,  
Ft. Walton Beach.

West Palm ARC, Roy Carter, -  
WA4SFF, 2320 Fairway Dr., West  
Palm Beach 33401.

I know your proud that you operate SSB. I used to lord it over the spark boys when I went CW. Someday I hope they reward you with a special carving attesting "SSB" on your tomb stone, but in the meantime let us keep peace in the family till everyone can see the light.

At the present time, I doubt if more than a dozen new SSB stations are being shipped into Florida and of course they are being bought up as fast as they arrive. If war continues another ten years, don't expect this condition to improve. I hope kits will be made more available if that will improve our know-how. This will definitely not improve our local dealer-customer relations, though, as kits are merchandised at practically no profit to the dealer, and some can be purchased only from the manufacturer.

Now you see the barren picture as it really exists. Dealers and manufacturers can not afford to advertise what they can not deliver. The antenna and tower people can not sell their goods unless you really need them.

Whether you are in the market or not, I suggest you scout around and see what equipment is available to get some idea of "where we are headed." It would be foolish to suggest buying up used equipment to be operated AM just because it is still legal. Why not consider CW for a moment? Most of this used equipment (AM/CW) will work very well on CW. Probably never again will it be made available. Think for a moment, High Level modulated stages (AM for instance) make real nice High Level CW Transmitters. Linears work on CW (33% efficient) but why not a regular high powered PA final with real efficiency? This means, "Buckle Down" and learn the code.

### Get On Frequency

With the advent of transceivers we have picked up a group of loudmouths who are forever shouting, "GET ON FREQUENCY." Most of these noisy individuals overlook the fact that what sounds good to their tin ear might not agree with someone else's tuning or a separate VFO is no reason for them to tell the rest of the world they are off frequency. Onyx

# One for the road,



## New National 200

**OR** . . . do you need a new rig for fixed-station use? Or a second or even third rig for vacation or even portable operation? Or a replacement for a single or tri-band transceiver? For that matter, the brand-new National 200 five-band transceiver, at only \$359, is a natural for *anything* that demands top-notch SSB, CW, and AM performance on the 80 through 10 meter bands with minimal investment. Traditional National Workmanship and our one-year guarantee are yours, in a five-bander priced even lower than a kit rig!

- Complete coverage of the 80 through 10 meter bands.
- 200 Watt PEP input on SSB, plus grid-block CW and AM.
- Separate product and AM detection plus fast-attack slow-release AGC in all modes.
- Crystal-controlled front end and single VFO gives high stability, plus identical calibration and tuning rate on all bands.
- Crystal lattice filter for high sideband suppression on transmit, and rejection of adjacent channel QRM on receive . . . plus solid-state balanced modulator for "set-and-forget" carrier suppression.
- Operates from new low-cost AC-200 supply (\$75.00) or from NCX-A or mobile power supplies.
- Extra features like: ALC; 45:1 planetary/split gear tuning drive; automatic carrier insertion in AM and CW modes; universal mobile mount included.

# AMATEUR RADIO CENTER INC.

"THE ONLY EXCLUSIVELY HAM STORE IN MIAMI"

**2805 N.E. SECOND AVE., MIAMI, FLA.**

MIAMI

OPEN ALL DAY SATURDAY 'TIL 5:30 P.M.

FORT LAUDERDALE

FR 4-4101

DON'T FORGET - WE BUY - SELL - TRADE - SERVICE

524-4484





Here is our Amateur TV Correspondent Monty K4VFX of Orlando adjusting his homebrew camera on a modified TV set monitor. Monty says he hopes to have another big ATV article for next months SKIP. Don't miss it. (Photo by W4PAO)

## Erroneous Impression

An Associated Press story on Docket 15928 has created the erroneous impression that some new action was taken on this docket. It was not an FCC or ARRL release but independently written by W3DEF of the AP staff to inform the general public. It is nothing new. Unfortunately choices for local headlines add to the confusion.

The story fails to differentiate between ARRL and FCC proposals. The League proposal was for reinstatement of the Advanced Class license. ARRL did not propose re-examination

### New ARRL Operation Manual

ARRL advises a new publication date for the OPERATION MANUAL is November 15th, 1966. Author, George Thurston W4MLE, SEC of W. Fla. in Tallahassee advises he will be in Miami area for Thanksgiving Nov. 24th. All those wishing to have a "Publication Party" with George contact W4ILE at 758-0882 or W4IYT at 888-3874 for details.

of amateurs as the story suggests.

To repeat: there is nothing new and the article is simply a recap of Docket 15928 developments during the past three years. (ARRL OB 80)

### S.E.T. Report

Here at deadline time (Oct. 10th) the Simulated Emergency Test reports are still coming in. Hurricane Inez didn't stop our Florida ECs from holding another excellent SET. Traffic moved smoothly on our phone nets and the state QFN (nightly on 3651 at 2330 and 0300 GMT) was loaded. Needless to say the National Traffic System operating on the half hour from about 1800 to 0300 GMT was busy on most all skeds.

Congratulations to all who participated and ECs are requested to turn in your reports to the ARRL and your SEC as soon as possible. Let's put Florida on top again this year.

We hope to have a full report for you next month.

## Letters To Editor

Editor, Skip:

I have read about your unique Dear Mabel award issued to long-suffering KYL's and tomorrow being the occasion of my own XYL's 46th birthday I would like very much to nominate her for this award.

Her full name is Dorothy May but she is normally called 'Dot' and of course her address is given above.

She has sustained me in my hamming from our courting days before WWII and one of the first presents I can recall her giving to me was an 807. This augured well for the future and so it has been through the 25 happy years of our married life. All the "sleepless nights, re-warmed meals, hot-coffee service" all go double together with a lot more such as entertainment and meals served up to my ham friends when they "drop in" always at inconvenient times.

I would say 75% of my success in DX chasing and contests I owe to Dot. So far she has never yet had time to go for ham radio herself but knows the Q code (for conversational purposes) and can recognize my call on CW without ever having learned what the dits and dahs stand for.

I will conclude by saying that of all the nominations you have so far received this one must be the most worthy.

Yours sincerely,  
C. R. Perks, G4CP  
Staffs, England

Editor, Skip:

Sometimes we amateurs enjoy our operations on the bands, never thinking or investigating how the operations are made simple and easy. I write this with two hams in mind—K4UGC, Fred and W4PWC, Bob, who have spent many countless hours experimenting and working on one of the amateur pioneer future bands, 1215 to 1300 MC. They have been having excellent results and have given several public demonstrations including the South and North Miami Radio Club. Much enthusiasm has been shown and their stations are always opened and available to all interested radio enthusiasts.

I would like to see Fla. Skip consider and award these two pioneering amateurs the coveted Fla. Skip Award for their outstanding work in amateur microwave.

Yours very truly,  
Walt Stock  
W4HS, Miami

Editor, Skip:

Was real interested in the article "Hammy Hams" by Leo Spaliozzi, W4VLN in the October 1966 SKIP.

I had many QSO's with the W6 Leo referred to when I was living in Atlanta several years ago.

The W6 call was W6SGP, Sweet Grand Paw, and issued the Cliff Arquette (SP) better known, as the old

codger on the Gary Moore Show who read the "letters" from Momma. He called himself Hemmett's powerful thirty watter. The usual report to a strong station was, "Rhode Island Red eleven."

It is pretty close to 20 years ago that W6GSP was real active on 10 meters.

So much for nostalgia.

73  
Herb Tuell, W4IRA  
Clearwater, Fla.

Editor, Skip:

Here is my 2 bucks for another renewal. Gosh these come around fast (getting old). Yet it seems at the end of the month that the SKIP just never gets here. I am always over anxious to see it.

Andy you asked if I have any pet peeves or squawks; yes I do. Not with "SKIP" but with the people that want to appear smart. I'm referring to those that use the word "Hertz" in place of "cycle per second."

Having been an engineer for very many years I'm sick of the U.S. method of measurement. Foot, inches, yards, pounds, ounces, quarts, gallons etc. The relationship of one to the other is very confusing. They tell me the foot came from measuring the foot of some English king; -- and this is 1966?

A real simple positive measuring system is the metric system. Everything in multiples of ten. Just simply add or subtract a zero for the next unit. Our own units in ham radio are part of the metric system. We use milli, micro, nano, and pico, also kilo and mega. Not the word "hertz". 95% of the people do not know why Hertz is famous. His name is not as well known as DeForest. But the words cycle per second is understood by all. It is self explanatory. Let's for heaven sakes not add to this foolish fad.

Our system of measurement in the U.S. is extremely confusing now, please don't make it worse. Use what you mean, CYCLE PER SECOND.

73's  
Frank W4TZY  
6985 Malaleuca Rd., Cocoa, Fla.

Editor, Skip:

Enjoy reading the SKIP monthly. I was a Florida resident from August 1933 to September 34 and operated W4CA at St. Petersburg and Maderia Island. Was very active on DX and rag chew bands, CW, and some 5 meter work with W4SK, who is now deceased (he was later K2GC).

Placed USA 2nd in ARRL SS in 1933 and had a ball from W4CAI. Spent winter of 60-61 in Ft. Meyers Beach and altho did not have rig with me, operated from the Everglades R. C. station (was a member) and other locals at Homestead.

Now live just outside Zion Park, in Southwestern Utah, in Washington County, a rare county in a rare state. Have legal limit on 15-20-40-75 and 80. Work lots of County Hunters on 14340, and active on 7255 WCARS Network, and also ASTRONET on 3885. Call here now is W7ZC. 73 to the old gang in Florida.

A. David Middleton, W7ZC/W5CA  
EX W4CA

### TRAFFIC MEN

202 STANDARD PADDED  
MESSAGE BLANKS ..... \$1.00  
100 MESSAGE CARDS ..... \$1.00  
WITH NAME AND ADDRESS  
IMPRINT..... \$2.00

POST PAID - PROMPT SERVICE

Florida Skip—Box 501—Miami Springs, Fla. 33166



## SCM's CORNER E/F

BY "HAM" K4SJK

Regarding Appointments

Most of you "eager beavers" have probably done some reading about the various appointments that are available to you from this office or from Hq ARRL but it won't do any harm to repeat some of it at this time.

Before proceeding I would like to urge all present appointees to keep close track of the endorsement dates on their certificates and to get them in to me when they come due. All appointments are for one years' duration and after that time, without endorsement, they are no longer valid. This office has been stretching several points in this regard in the past but now that I am ending my tenure of office soon I wish to be able to turn over to the new SCM a clean slate in accordance to the rules by which he may desire to operate.

To go a bit further into the "keep qualified" bit may I remind all that it is expected that a reasonable amount of activ-

ity be indulged in and, even more pertinent to remaining qualified is that pesky monthly report. If I don't get your report each month I must assume that (1) you are deceased; (2) you are almost deceased; (3) you left on vacation; (4) you got married OR (5) you just are no longer interested. Please help me keep things up to snuff until the new SCM takes over. Makes it much easier for him to carry on.

No sense going into detail about appointments either. The printed info in the booklet "Operating an Amateur Radio Station" tells it better than I could and if you have any additional questions I can answer them for you. If you don't have a booklet just ask me for one. They are free. Besides I'm rapidly running out of space. You VHFers should look into the new OVS appointment certificate. Doing fine on 00s now but can use more. 73

### Nominee For Eastern Fla. SCM

Jesse H. Morris, W4MVB, Age-31, Bachelor, Field Engineer, Philco Tech Rep Div.

Born in Stilson, Ga. in April, 1935.

First licensed as W4MVB in March, 1960. I operate CW and SSB on all Amateur bands from 80M through 432 except 220 MC. I am active in emergency work and traffic work. I am an active DXer and I operate on the UHF bands. I am particularly interested in the higher UHF bands.

I am a past president of the Beaches Amateur Radio Society, a past president of the North Florida Amateur Radio Society. I am currently president of the Florida Side-Banders Assn. and a past secretary of this organization. I am also currently a member of the Board of Directors assistant EC in Duval County. I hold OES and OBS appointments. I am editor of the Florida DX Club bulletin "FLORIDA DX CLUB REPORT". I am also editor of the North Florida Amateur Radio Society bulletin "BALANCED MODULATOR." In addition I edit the Beaches Amateur Radio Society "NEWSLETTER".

I am active on the air on all bands several hours per day. I am a net control station on the Duval County Two Meter Emergency Net and the Florida Amateur Side-Band Traffic Net.

I am interested in continuing the leadership K4SJK has provided in making Eastern Florida the top Section in the country in traffic work. I am interested in continuing to work with the leaders in emergency work in the state who have made Eastern Florida the model for other emergency operations. I am also interested in increasing the use of VHF for emergency and traffic work on a state level by the use of long distance VHF networks.

I am an ARRL member and have been since I was licensed in 1960. I am a staunch supporter of the League and would like to see more people take a part in League affairs. If elected as SCM of Eastern Florida I will be available to help anyone with problems falling under the jurisdiction of the SCM's office.

SCM ballots will be mailed next month.

# TROPICAL HAMBOREE ARRL FLORIDA CONVENTION

January 21-22 1967

"WHERE THE LATEST IN  
HAM GEAR IS SEEN FIRST"

*Bayfront Auditorium*

### PROGRAM INCLUDES:

- \* TECHNICAL TALKS
- \* RAG CHEWS
- \* SWAP TABLES
- \* AUCTION
- \* OLDTIMERS & QCWA
- \* MARS MEETINGS
- \* ARRL MEETINGS
- \* CONTESTS \* BANQUET



**REGISTRATION \$1.50**

TICKETS PURCHASED  
BEFORE JAN. 1, 1967  
2 for \$1.50

## DADE RADIO CLUB INC.

BOX 73

MIAMI, FLA.

33152

# CLUB NEWS

## NOMARC

By Mel, WA4NHT

Classes for Novice ticket are going along pretty well. Tests were given a couple of weeks ago to two students and they had no trouble passing. 14 are in the class at present and it looks like all will be passing soon. Glynn, WA4LHK and Brian, WA4VZY are doing a good job of instruction. General class theory is also being covered and every one concerned really enjoyed the class. New students will get separate instructions to help them catch up to the more advanced, so if you know of any one that has a desire to be an amateur send him or her around to the club house on a Wed. night at 8:00 P.M. No charge of course and everyone is welcome. 776 N.W. 125th St. is the address. Clubroom is in the basement of the City Hall.

On Nov. 3 at 8 P.M. Mr. A. Gilbert Chief Engineer of the F.C.C. will honor us once again by being our guest speaker. Mr. Gilbert will lecture on "Direction Finding" and if it's half as good as his last lecture it promises to be the most enjoyable night of the year. His last lecture on "TVI" was really great and with the fine turnout we had then it was enjoyed by all. So come on down, all are invited, plus free coffee and cake.

We had some pretty good movies in the past couple of weeks. Films on Transistors, Crystals and Solar Batteries was shown.

Arrangements being made for an endless supply of films for the club to be shown on Wed. nights. We are also trying to obtain films that will be of a benefit to the Novice groups as well.

Members were kept pretty busy counting QSL cards from the returns of Dade County Amateur Radio Week and this weekend all will be busy mailing out the certificates. So be patient fellows you should get them next week.

## GAINESVILLE NEWS

By Bill Wells, K4RDF

My apologies for not submitting an article lately. Many things have

been happening and all at once, so let's see if we can make it all up in one try.

At a recent Annual Family Picnic of the Gainesville Amateur Radio Society, Mich Hudson, W4UW was awarded our club's coveted MOST OUTSTANDING Award. This award is given only after written recommendations by the members and a committee makes the decision of which member is most deserving. Mich also won the OUTSTANDING CRAFTSMAN Award on the basis of his "home-brew craftsman" abilities. He submitted a beautifully built 2 meter linear amplifier. This is decided on a Points System.

Yours truly was the winner of the Club Insignia contest. Maybe AC will reproduce a black and white replica of same when one can be made in a suitable size for reproduction. (Let's try it. AC)

Operation SET this last weekend was a success in this area with all 10 meter base and mobile stations participating.

Transmitter-Hunts have been re-activated in this area and we're having a ball. Interesting indeed are good places discovered while looking for the hidden transmitter. We recommend staying away from cattle livestock markets tho, they'll give you away every time.

Sunday night F M Net for this area working out real good. At least 15 check-ins from several adjacent counties and John W4GUJ in Jacksonville also most every time.

Alachua County Radio Officer is now Mich, W4UW. He is really "pushing" AREC/RACES in this area and is also our EC, and getting good cooperation from other area EC's. Have reason to believe that a good exercise involving several counties is in the planning stage. Til next time.

## TAMPA CLUB

By Marvin M. Bostain, WA4HDK

TARC had two fine programs at their regular October meetings. On the 3rd, Ralph Coady, W4BNI, arranged for Major Harold Johnson from

MacDill Air Force Base to speak to the club on "Antennas." Major Johnson has made this presentation to other groups and has always been well received.

On the 17th, Frank Haines, WA4-GDS arranged for "Ham" Hamel, K4SJH, our Florida SCM, to talk on Traffic Handling and Amateur Communications. Ham is always well received at any club meeting.

For some time TARC has been working with the Florida Council for Retarded Children and has been planning to construct some communication devices that can be used by these children. The project has been pushed by Earl Miller, K4HFF. Earl has finally received a sample from the Cleveland Electric Illuminating Company, who originated the project. In a future article we will go into detail on the device.

Although it is early, TARC's big project, the fair booth at the Florida State Fair, is organized and rolling. The committees are headed by John Fogarty W4CI, Jim Bingham W4KRC, Ralph Coady W4BNI, and Earl Miller K4HFF.

## VBARC

By Dennis Yantz WA4YFY

October 6th marked the election of new officers at VBARC. Richard Jackson, WA4RQB, who has done a real job for the past two years was again unanimously re-elected president. Our new vice-president is Rev. Gall Norris W4GJT, who joined our club several months ago. Yours truly has given up the job of secretary to a qualified young man; Connie Hamlin WN4COM. George Jones, WA4QVJ, has been taking good care of our money for the past few years so we re-elected him treasurer. We other club members are very confident that our organization will continue to grow and prosper under these fine gentlemen.

I. J., WA4SCK our EC gave a very informative talk on the upcoming SET. We hope to make this test a real success for Indian River County.

73 Dennis

## WESTERN FLA. NEWS

Frank M. Butler, Jr. W4RKH

Pensacola: W4AXP is getting bugs out of SX-101, with help of W4IPV. K4SOI has his SB-200 going, but is seldom home long enough to use it. W4NOG is building new ham shack.

K4COV's FB hamshack is complete with paneled walls. WA4BYI is still QRT with rig trouble.

Milton: K4NMZ got tired of commuting and moved to Pensacola. Hurry and get those antennas up, Bob!

Fort Walton/Eglin AFB: The W. Fla. Net picnic drew a nice crowd of about 80. Several prizes were donated by the local clubs, Eglin ARS and Playground ARC. EARS is having to move from its present building at Eglin, but should be in new, larger quarter soon. WA4HNI retired from the Air Force and is devoting full time to hamming.

Panama City: Six mobiles took part in the first 2-meter transmitter hunt; W4 FOX won the prize. W5MPK/4, the hidden bunny, held an open house at Lyndall after the hunt.

Defuniak Springs: K4VWE and WB4BYO have ordered gear for 2-meters. W4JOZ has taken up sailboat racing.

Marianna: Your SCM visited old timers W4AIA, W4IRO, W4PHV and K4ZTQ; all promised to be back on air soon. WA4DED, who has been sick, is missed on WFPN.

## INDIAN RIVER

By D.R. Klobe WA4KJV

What a busy month. When this club was re-activated a short time ago things started to move and they haven't slowed down yet.

To start with, I am sorry to say that Roy McKibben, K4CLZ has left the area. We hated to see him go. Roy was a very active member of the club and was very instrumental in its re-activation. The club held a fish fry on Merritt Island in his honor. I didn't count them, but I think every member of the club was there and then some. The fish fry was quite a success and some said they had as much fun as they have had at field day's. From the conversations that were going on about "hey, remember that antenna we tried to put up in that tree and the tree fell down" etc., it sounded like a field day. Best of luck Roy at your new QTH.

Owen Wallace, WN4CLI while on vacatin in Boston stopped in at the F.C.C. office to see what he could do about that "N" in his call. Welcome to the general class of hams WB4-CLJ.

Norm Holzweg also while on vacation took a trip to the FCC office in Miami. Norm is no longer an as-

# BARBECUE & AUCTION!

Sponsored by  
the  
FLAMINGO NET  
MIAMI

PBA GROUNDS - 2300 N.W. 14th ST.

Sat., Nov. 5

AUCTION STARTS 2 P.M. BARBECUE SERVED 6 P.M.

TICKETS AVAILABLE AT HAM STORES,  
NET MEMBERS & AT DOOR



# CLUB NEWS

sociate member of our club. He is a full member now. Welcome to the ranks WB4EBH (early Bird Holzweg). Our club meets on 3825 KC and 146.87MC every Sunday morning for a good rag chew. All Florida hams are invited to check in and get acquainted with the gang in this area.

## FT..MEYERS CLUB

By Ken, W4SMK

Local doctors W4PJJ and K4CAH went down to Cayman Island for the DX contest, operating as ZF1EP. They took along two complete Drake stations and should come up with a FB score.

New officers for the FMARC are Doc Ernie Hendry, K4CAH, Pres; Howard Daubman, WA4LFZ, VP.; and Harry Fishel, W4CQZ, Sec. This is the start of a new year for the club, and it promises to be a big one with lots of plans for activities. See our club ad in SKIP for more info. Visitors are always welcome.

Don Wright, WA4LBM left for the Air Force last month. Don is one of our good cw ops and also holds a commercial ticket. We will miss him, and wish him lots of luck with his new job for Uncle Sam.

Between the national S.E.T. and that fickle lady Hurricane Inez the local AREC and CD had a pretty good work out last month. Our sincere thanks to those who helped us sweat it out. Earl Spencer, K4FQU, is the Red Cross Radio Officer; Bob Cornwall, W4HSG is RO for CD; and W4-SMK is EC. We have 26 members in the AREC.

Sorry to report that Leon Walters' (K4GLS) son has been seriously ill, but is getting along a little better now.

I was saddened to read in last month's SKIP that one of my old 40 meter cw friends, W4FRZ, Russ was a Silent Key. As the BARC people said in their column Russ will really be missed with that fine first on cw.

We all enjoyed W4IYT's visit to the club last month. Since then AC has been in and out of the hospital for a check up and trust he will be doing OK. Don't forget to nominate and vote for a good man to replace our SCM, Ham who is not running for office again. Thanks to K4SJH for a difficult job well done, and luck in his Assistant Director position.

73 Ken

## B.A.R.C.

By Jim Wilson, W4GDK

A fairly calm month of Club activity was broken up by the arrival of Hurricane Inez. Hank Roth K4EVY our County Emergency Coordinator got his crew of operators into action during the night as it became apparent that Inez was turning toward land. Mobiles were dispatched to the many

important points where communication was essential.

So much traffic was handled during this 12 hour period that the following operators won the coveted Broward County Emergency Net Certificate: WA4HXT, Harry Raymond; WA4UYO, Ken Nordine; and WA4WVC, John Brott. Congratulations!

With the approach of the years end, the nominating committee has been busy lining up a set of new officers. Of course there may be nominations "from the floor" and the Club is pretty well assured of a fine group of workers.

Our banquet is coming early in December and at that time the Broward County "Amateur of the Year" will be announced and suitably recognized.

To help newcomers in ham radio and those who want to progress, the Club is running an instruction class at 8 PM the fourth Wed. of each month at Chaminade High School in Hollywood. At the September class there were 20 prospective novices and 6 working toward their General tickets.

Our regular meetings are held at 8 PM the second Wednesday of each month at the Broward County Medical Assn. Building at 2200 South Andrews Ave., Ft. Lauderdale. All are welcome.

## FLAMINGO NET

By W4EDP

Since the last report the Flamingo Net has been busy as usual with normal activities, curtailed only by absences for vacations, etc. A transmitter hunt was held on Aug. 28, which was won by W4DTJ and CO, and another was held on Oct. 28, which was won by WA4BPX. On Oct. 28, the hidden transmitter was W4DTJ and the scoundrel located himself in a little part on the West end of the Julia Tuttle Causeway that can only be reached from 37th St. Since the hunt started in Miami and the signal was coming from the East nearly everyone went East on 36th St. and once on the causeway found to their surprise that they had gone past the station and had to drive all the way to Miami Beach to turn around. Everyone, that is, but the winner WA4BPX, how he kept out of that trap I'll never know.

The last couple of Net meetings the talk has been largely about plans for the annual barbeque and auction, and it looks as though everything is set. The affair will be held in a new location this year, a very nice place with everything necessary to make it a success. The place is the P.B.A. park at 2300 NW 14 St. The date is

Saturday, November 5. The auction will start at 2 PM and the barbeque will be served at 6 PM. So figure on coming and meet all your friends. Clean out the junk box and bring something to auction too, while you are at it. Tickets are available from net members and both Ham stores.

Before signing off I would like to thank everyone who came to visit me or sent me cards during my recent confinement in the hospital. It is nice to know that so many people thought of me when I needed it. Thanks again and 73. Jim

## SUNCOAST ROVING REPORTER

By Cathy Soehl, W4BAV

The Suncoast area was well represented, at Peace River Park, Sept. 11th. Winter Haven, Leesburg and many other areas were represented. A good time was had by all, lots of nice prizes and K4EBO-Lucky did a fine job MCing the Hamfest. Glad to report the rain held off.

Belated congratulations to W4OJH-Don Summers on his recent marriage, after so many years of bachelorhood. W4EJY-Hal advises the hurricane tore his beam up and he is interested in obtaining a 20 meter beam. Anyone knowing of one contact Hal Clayton, 1025 60th St. So., St. Pete., Phone 345-0294 or Girard Jewelers Ph: 898-4596.

K4BNE-Rick is doing a tremendous job on his weekly column, "The Ham Shack" in the St. Petersburg Independent. One item he requested everyone to clip and send to ham friends outside of Florida. Quote: "A new traffic net, handling messages all over the world needs hams in several states to check in and help move the traffic. Outlets needed in Ky., Ark., Mo., La., Pa., Md., Del., N.M., Conn., West. Va., Ind. and Vt. Net meets 7 nights a week at 10:30 PM EST at 3950 KC. Net called So. Atlantic Traffic Net (SATN)." Anyone giving an assist on this will be appreciated.

Welcome home W4NOK-Jack and XYL, WA4NFA-Frances, after a busy, hectic summer operating your hotel-motel in Ocean City, N.J. We are sorry to hear Frances is not well and hope she will soon be off the crutches.

Sorry to hear W4IE-Charlie had his rig burned up by lightning and hope he will soon be back on the air. Know he is greatly missed, as he handles much traffic.

Congrats to WB4AIW-Elmer on a fine write-up, with picture, in the Sarasota Herald-Tribune, Oct. 1st.

He recently received the coveted Medallion of Award from ARRL. To be eligible for this the operator must handle a minimum 500 messages a month. Elmer handled 946.

## NOFARS NEWS

By Jesse H. Morris, W4MYB

North Florida is busy getting ready for the annual Jacksonville Fair. This year Amateur Radio will be part of the Fair. Thanks to the efforts of our President W4PLE, we will have a booth on the floor of the Coliseum for the run of the Fair which lasts from October 19th through October 29th. It is expected that 190,000 people will visit the Fair this year and this is another good opportunity to make the public aware of Amateur Radio. John Witherspoon, W4GUJ, is chairman of this effort and we hope all will turn out from this part of the state to help with the booth. We expect that the booth will be visited by Mr. Chuck Bolvin, W4LVV, Southeastern Division Director, on the afternoon of October 22nd.

We are looking forward to a visit of another ARRL official this month as Mr. A. L. Hamel, K4SJH, Southeastern Division Vice-Director and Section Communications Manager for Eastern Florida will be the speaker at our regular October Meeting on the 13th.

NOFARS and the Duval County AREC along with members of the Beaches Amateur Radio Society took part in another public service project last month. On September 25th sixteen members of these organizations assisted local teenagers to collect donations for the aid of crippled children. The occasion was an AL-SAC drive, a national organization whose chairman is actor Danny Thomas, directed by a local television personality, Virginia Adder. Ron Locke, W4YFX, was chairman of the Amateur radio effort. Those people participating were: W4YFX, WA4WPQ, WA4VZF, W4PLE, WA4PNG, WA4EYU, WA4MTQ, WA4MRK, W4NMG, WA4WOW, WA4UQO, K4LEC, WN4BTO, WA4SGF and W4GUJ. The operation, which was covered by local radio and tv stations, collected about \$14,-500.

That is about all for this month. Until next month good luck and 73.

## WEST PALM BEACH

BY JOHN BENAMIN

Well here it is, October. This is the month for witches and ghosts

(Continued on Page 11)



# SURPLUS

## ELECTRONICS

# THE HAM SHACK

OPEN ALL DAY SATURDAY

2211 N.W. 36th ST. NE 5-0378 MIAMI, FLORIDA

# Der Pippensqueaker

By Geo Thurston W4MLE

(PART III)

## POWER SUPPLY

A single transformer furnishes B plus for all stages and a small filament transformer "turned around backwards" supplies bias. The B plus supply is somewhat unconventional.

It uses strings of silicon diodes in a standard full-wave bridge circuit to give 800v (key down) for the 807, but this is too much for the other stages. They are supplied from the transformer center tap, which is independently filtered and furnishes about 450v (key down). The unused 5 v. winding on the transformer is hooked up to "buck" the primary voltage in this position, otherwise the key-

up voltages would have exceeded the ratings of the h.v. filter capacitors (1000 v.) A second position of SW-2 ungrounds one leg of the bridge, ground the center tap instead and transfers the low voltage filter network to parallel the high voltage filter. The supply then furnishes about 450 v. d.c. (key down) to all stages, including the final. When the final is run at 25 watts input, this is the setting normally used.

The voltage regulator tube furnishes regulated 150 volts to the v.f.o., isolation amplifier and T/R switch. Only the v.f.o. needs the regulation but the other two require plate voltages in the order of 150 volts and this was a convenient source.

Only capacity filtering is used. There are no filters inductors. This resulted in some reports of slight ripple when the rig was first put into service. The ripple was completely eliminated by the use of a 100 mf/450v. electrolytic in the screen voltage divider where the final screen and driver screen have a common source. This was done because the key up voltage (520 v.) exceeds the ratings of readily available electrolytics and no further room was available for 600 v. pyralon capacitors on the chassis. Another 100 mf electrolytic was added in the VR tube dropping resistor string for the same reason. Dynamic regulation is greatly improved thereby. The filter could not

be added in parallel with the OB-2 of the probability of a relaxation-type oscillation.

The silicon rectifier units are standard 600 piv, 750 ma units, connected in series strings. Each unit is paralleled with a .01 capacitor and a 330-k half-watt resistor to reduce back-voltage differentials and swamp out transient spikes. The rectifier is assembled on a piece of vector board, with 10 ohm 1/2 watt resistors in series with each leg. The switch (SW-2) is ceramic. No secondary winding is used either to buck or augment the primary of the transformer when SW-2 is set for low-voltage operation.

## METERING

The meter is a conventional 1-Ma. unit (internal resistance 40 ohms). Shunts were wound by calculating the length of wire required to produce the proper resistance. Meters with diff-

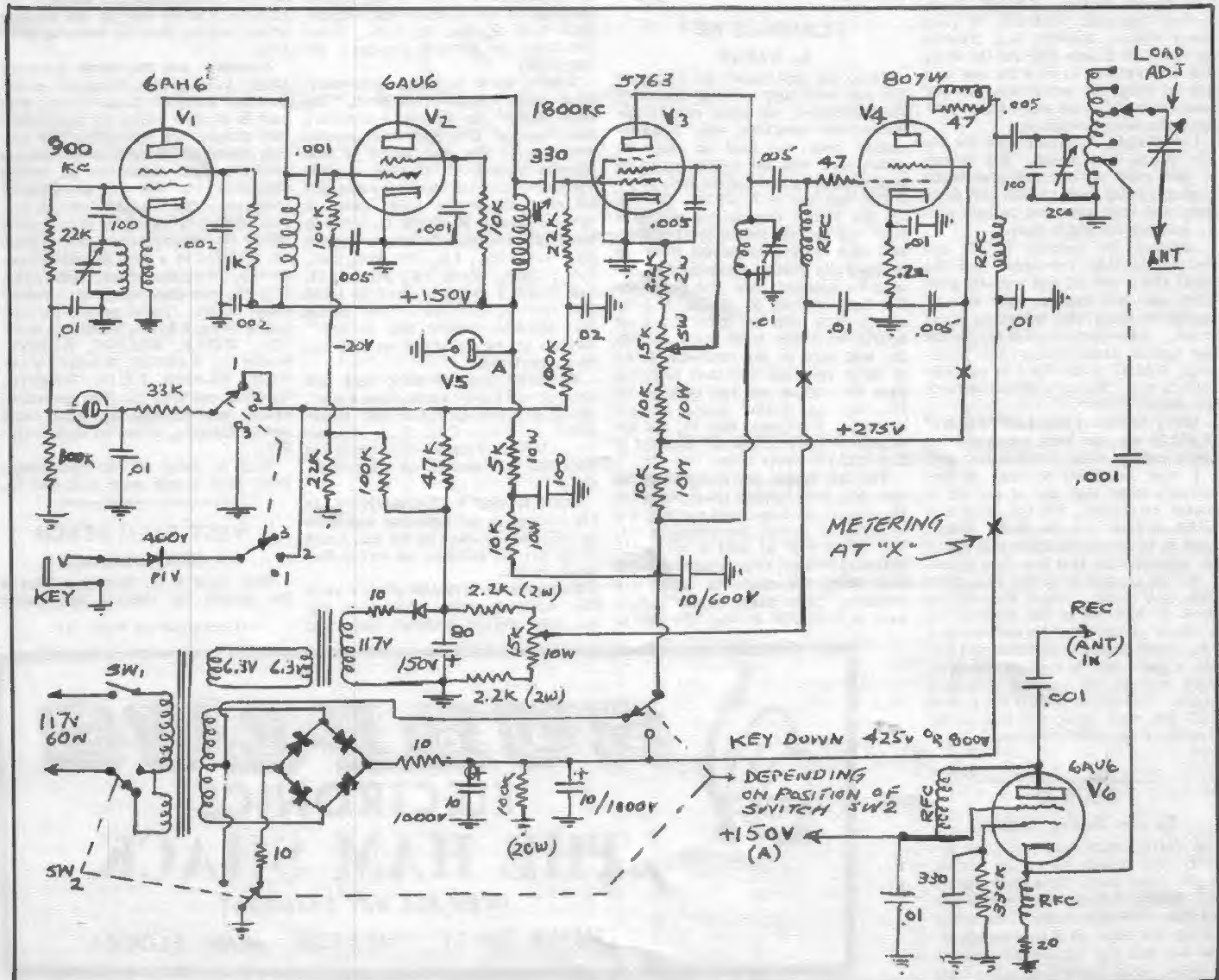



erent resistance or sensitivity would require different shunt valves.

The volt-meter (0-1000) uses a 1% one-meg resistor for a multiplier.

The grid current meter has a range of 0-10 Ma.

The screen current meter also has a range of 0-10 Ma.

Plate current has a range of 0-100 Ma. this meter is not a cathode circuit because at these low power input levels, grid and screen currents are a big enough proportion of the total to make cathode current readings grossly inaccurate.

A cathode current position is provided (0-200 Ma.) however, for use, if desired, at higher power levels when the operating plate current may be 100 Ma.

The r.f. voltmeter is intended to provide only a relative reading of output voltage. It can be used mostly to see whether maximum output occurs somewhere near minimum plate current.

A neon lamp on the panel is capacity coupled to the final tank and thus gives a positive indication of r.f. output voltage from the tube. The "filament" indicator lamp is a neon bulb connected through a high value dropping resistor to the high voltage supply, which comes on as soon as the transformer primary is powered. It thus gives a positive indication that the power supplies are all working. (Bias voltage failure might occur independently, of course, while the h.v. remains on, but this would result in r.f. output from the final, with key up, as well as positive indications on the meter at all settings of the meter switch.)

#### TUNE-UP

Tune up and operation are simple. A 40 or 100 watt lamp bulb may be used for a dummy load. With SW-2 in the "low voltage" position, the key is depressed and the final tank is quickly resonated, if possible, using the r.f. voltmeter and tuning for maximum meter deflection.

When this has been done, again depress the key and tune "driver tuning" for maximum grid current on the 807. Adjust the drive with the pot ("Adjust Drive") to give a static grid current reading of 3 to 4 ma.

Recheck final plate current, adjusting "Final Amp Tuning" for minimum plate current. This minimum should never exceed 100 Ma. If it does, ad-

just "Antenna Coupling" and/or "Load Adjustment" to reduce the current below 100 Ma. and re-dip the plate current, with the "final amp tuning."

The light bulb should glow from dim to brilliantly depending on the rating of the bulb and the loading of the transmitter.

Now transfer the rig to an antenna and readjust the coupling and load adjustment to give the proper loading, always re-dipping the plate current with "final amp tuning" after each load adjustment.

For higher power operation (as in the daytime), TURN OFF THE POWER. Switch SW-2 to "high voltage" position after the filter capacitors have discharged, and turn power back on. Changing SW-2 with the power on results in severe arcing and possible damage to the switch and other components.

Follow the same tune-up procedure as before. Plate current should not exceed 100 ma after dipping it at maximum load. Preliminary tune up is best done using the cathode current position, because of its higher range. Off-resonance adjustments often result in plate currents which would pin the 100-ma meter.

Fully loaded, the 807 will draw 100 mills of plate current at 750 to 800 volts on the plate -- or 75 to 80 watts input. Grid current should always be between 3 and 4 ma.

#### T/R SWITCH

The T/R switch is built into the transmitter to supply a signal to the receiver when the key is up, if desired. Or, of course, a separate receiving antenna may be used.

Key up, the 6J6 or 6C4 (V-6) operates as a grounded-grid class-A amplifier, feeding small received signals to the receiver. Key down, the grids draw current, developing a high self-bias through the grid resistor, cutting off plate current flow and protecting the receiver from r.f. damage.

## New Daytona Beach ARA Officers

The following new club officers were elected September 19 in DBARA. K4ESI, Pres., W4OQX Vice Pres., WA4RIH Secy., W4PGL Treas., and W4JCP Activities Manager. Their club call is K4BV which was active in the Oct. SET.



Another ex-snowbird retired in Florida. Jim Nicholson, W4BU, ex-W1BRU, now lives year 'round in Sarasota. Jim, while not fishing, can be found talking to his Northern friends and around the state on 75 SSB. Welcome aboard Jim and enjoy yourself.



## ARMY MARS

By AD4VWY (Will)

Pat, AA4AO, reported Sept. 23 that he had been in a hospital ten days for hernia operation and repair; also that he was getting around rather nicely. We are all very thankful to hear the good report.

AA4ZNV, "ED" Edson of Arlington, Virginia, who has been in and out of the hospital a number of times in the last eight years, accompanied by his XYL Eula, expect to drive to the Sunshine State the end of October and visit this writer.

Did you ever look a vicious intruder straight in the eye and live to tell about it? Well, come to think of it, Lew, was in the eye of a hurricane and he took a good look and lived to tell us about it.

We were mighty glad to hear from Bob, AA4JZ, that his XYL Tomi was somewhat better, although she has to return for periodic checkups. We all should pray for them.

Perhaps you have heard about the "new math" that is being taught nowadays. Well, this

writer still has trouble with his "guzintas"; you know - two guzinta four two times; two guzinta six three times; etc...! Too late smart - too soon old.

AA4SJK, Ham, gave an interesting talk at the Vero Beach ARC.

AD4ESL, June didn't try to put her foot in her mouth. She insisted it collided with a door and caused her great pain and anguish, the latter probably from conjectures during the comment period on net.

Our experimental 3-element inverted "V" 20-meter antenna, part of which was in the middle of a large holly tree, has been doing a fine job. Listened 40 minutes to a lad at South Pole talk with his father in Alexandria, Virginia, following which the latter patched us in to A3ECP, Van the SMD, Maryland.

Word has been received that the XYL of AD4GWW has been in hospital also. We hope that she, too, is getting well.

AL4AHR, Len, says his wife is getting better also.

## Grid Leaks

Doesn't it amaze you that with all this so called expert criticism heard on the ham bands that the manufacturers of amateur radio equipment can still stay in business?

Wonder if both sides are protected by the cliché that the Good Lord takes care of children, drunks, and damn fools!

Onyx

FLORIDA SKIP, November 1866 9

# MARS

## MEMBER OF THE MONTH

By Will AD4VWY

Biography of Chester E. Watkins, AA4KKZ, the Ole Man Onna Mountain;

Chet was born in Ashland, Ky., in December 1893 and attended high school there briefly. In 1910 he became interested in radio and later in color photography. In 1912 he came to the Ft. Pierce area with his parents who bought a citrus grove.

In 1916 a Capt. Willoughby installed in his yacht radio telephone equipment built by Lee DeForrest. When Willoughby's son donated this equipment to the House of Refuge in 1956, it was none other than Chet who overhauled the equipment and put it in working order.

In 1959 the Ole Man Onna Mountain furnished OA4CS, Chief Pilot of Fawcett Airlines in Peru, with its first amateur radio teletype equipment. In that same year he received an Award of Merit from the Florida RTTY Society for being chiefly instrumental in rushing much-needed medicine to a 12-year old unconscious boy in Peru who, as a result of this prompt action, regained consciousness three days later and fully recovered in another 15 days. In 1958 Chet was also instrumental in delivering medicine to the Commandant of the Peruvian Air Force for use by an air-force pilot who had cracked up.

On April 2, 1960, Chet came to the assistance of two sailors stranded in Nicaragua after they were robbed and left penniless. His prompt action caused a friend to cable \$60 so that the lads could return to their base in Green Cove Springs, Florida.

A month later cartoonist Zack Mosley featured K4KKZ in his colored comic strip "Smiling Jack." In 1965 Chet assisted at the time of the Good Friday Alaska earthquake.

Among his many awards we list: Life Membership, Peruvian Radio Club; charter member, Knights of Kilocycles (no connection with the Knights of the Mystic Sea of bygone years!); several certs. of merit from Dept. of Defense; and American National Red Cross for services during Hurricane Cleo.

His present specialty is AR-10 FLORIDA SKIP, November 1966



Very active in the Gainesville area is George Putnam WA4UJX, better known as "Doc." Dr. Putnam works the traffic nets and is always ready to help out when needed. He is Diplomate American Board urology - F.A.C.S., M.S. University of Chicago (1934) B.S. Howard College, B Law 1929. Look for Doc on 75 SSB.

## What's New On Six?

Practically nothing this month. No skip, no correspondence, no nothing. Unless you guys and dolls wake up we may just drop this column. Heard some comment on the air (on six) but the general opinion was to get your reports in early to QST, after mentioning 'skip' by mistake for QST.

From QST we hear VP7DD located on Carter Key has an AØ Standard Frequency signal on 50.0015 MC. Omni-directional antenna with 1-KW input.

For you SSB boys on 50.150 here are some fills for your WAS project. These boys QSL and have been on during the past year with good SSB signals, on the low end of the band mentioned above. California WA6-HXW, Ariz. W7RVY, S.D. WØC-VC, Colo. WØDK, Neb. WAØIWF, Okla. K5VRL, La. W9JMS/5, Iowa KØIDY, Nev. K7ICW, Maine W1GJZ, Vt. W2NOF/1, NH K1-UHJ, Mich. W8LKM, SC W4C-PX, Kans. WØCSO, Mo. WAØF-OL, Wisc. W9CIU. We have many more for next months column.

W1GJZ, Vt. W2NOF/1, NH K1-UHJ, Mich. W8LKM, SC W4C-PX, Kans. WØCSO, Mo. WAØF-OL, Wisc. W9CIU. We have

MY MARS, particularly 6 & 2 meters.

Anyone who has seen the vast quantity of intricate and other equipment in Chet's shack can readily understand why the XYL insists that he confine his hobby to a separate building.

many more for next months column.

Arkansas still seems to be a hard state to get a card from, AM or SSB. From South Florida, SC seems to be about impossible due to critical short skip. VE3CUZ, VP7DD, KP4-BRJ are on SSB and do QSL promptly.

Two SSB boys got lonesome on 50.150 and sneaked up on 50.250 the other night. A local Am boy was invited in but he complained heartily of the bad audio and extreme distortion. It was lousy SB with poor lower SB rejection. There is no excuse for this. We would like to see everyone on SSB and urge you all to plan in this direction, but please use a little humility and not crowd the AM signals off from 50.250 or we may have to desert this frequency for our International AM Calling Frequency. See you next month.

Susan-Item-Xray

### Printer's Ink

Is the electric auto, not made in this country since 1928, about to stage a comeback? Maybe.... at least, the technology to make them practicable is on the horizon.

Biggest impetus for an electric car, if it develops, will be the smog problem. It would, at one fell swoop, eliminate a major cause of smog. Reportedly, one major Detroit auto company has an advanced research group looking at the idea.

# FLORIDORA



By Cathy Soehl - W4BAV

**ATTENTION FLORIDORAS:** The regular on the air business meeting has been changed to 9:00 A.M. EST, the first Tuesday of each month. Previously it was called at 8:00 AM. Another change is that the limit on applications for stickers for the Floridora Certificates has been removed.

Floridoras enjoying the annual Bartow VHF Hamfest, held Sept. 11th, at Peace River Park, were; K4LPV-Irene, WA4EDL-Nancy, W4BIL-Fran, WZ4KYA-Vivian, W4WPD-Shirley and W4BAV Cathy. WA4KYA-Viv was the lucky one in the crowd, winning a Turner super, transistorized microphone.

K4RDX-Betty, a former Floridora, attended the Bartow Hamfest and told W4BAV she was sorry not to continue activity in the Floridoras but OM, Dutch-K4RXV had suffered a heart attack sometime ago, though we are happy to report he is doing very well now, and that she was working so had to forego her hamming. Betty says she intends to go for her General Class license as soon as she can arrange it.

W4WPD-Shirley and OM, Earl -W4UFR drove son Russell's car to Long Island, N.Y. in October, and flew back to Tampa. Russell is working at the Kennedy Airport and has an apartment in Jamaica, where they will visit a few days.

WA4FJF-Ellen reports she is busy with scouting. Her OM, Dick-WA4FLJ has been in Greece, among many other places on his assignment and Ellen has not had too much luck contacting him. Welcome back to the States, Dick!

W4EHN-Betty has returned from their 10 weeks trip and says they had a fine time, though the 1st three days she had to do all the driving as OM-Clem was sick. After that she had a "ball" mobiling and contacted 7 YLs. Welcome back.

K4TBG-Kay has added a Swan 250 to her shack, so keep an ear for her on 6-meters. Kay is doing O.K. as you will recall she purchased a Swan 350 at the Orlando Hamfest, so she is active on Navy Mars. Congrats, Kay.

**STATEMENT OF OWNERSHIP,  
MANAGEMENT AND  
CIRCULATION**

(Act of October 23, 1962; Section 4369, Title 39, United States Code)

1. Date of filing: Sept. 26, 1965

2. Title of publication: Florida Skip

3. Frequency of issue: Monthly.

4. Location of known Office of publication: 41 Lenape Drive, Miami Springs, Fla.

5. Location of the headquarters or general business offices of the publishers: 801 West 49th St., Hialeah, Florida

6. Names and addresses of publisher, editor, and managing editor: Publisher: Don Simcox and Associates, 801 West 49th St., Hialeah, Florida. Editor: Andrew Clark, 41 Lenape Drive, Miami Springs, Fla.; Managing Editor: Same.

7. Owner: (If owned by a corporation, its name and address must be stated and also immediately thereunder the names and addresses of stockholders owning or holding 1 percent or more of total amount of stock. If not owned by a corporation, the names and addresses of the individual owners must be given. If owned by a partnership or other unincorporated firm, its name and address, as well as that of each individual must be given.) Name: Florida Skip, Inc. — Non-profit

8. Known bondholders, mortgagees, and other security holders owning or holding 1 percent or more of total amount of bonds, mortgages or other securities. (If there are none, so state). None.

9. Paragraphs 7 and 8 include, in cases where the stockholder or security holder appears upon the books of the company as trustee or in any other fiduciary relation, the name of the person or corporation for whom such trustee is acting, also the statements in the two paragraphs show the affiant's full knowledge and belief as to the circumstances and conditions under which stockholders and security holders who do not appear upon the books of the company as trustees, hold stock and securities in a capacity other than that of a bona fide owner. Names and addresses of individuals who are stockholders of a corporation which itself is a stockholder or holder of bonds, mortgages or other securities of the publishing corporation have been included in paragraphs 7 and 8 when the interests of such individuals are equivalent to 1 percent or more of the total amount of the stock or securities of the publishing corporation.

10. This item must be completed for all publications except those which do not carry advertising other than the publisher's own and which are named in Sections 132.231, 132.232, and 132.233, Postal Manual (Sections 4355a, 4355b, and 4356 of Title 39, United States Code)

Average No. Single copies each issue during nearest preceding to filing 12 months date

A. Total No. Copies Printed (net press run)	1560	1560	E
B. Paid Circulation			F
1. Sales through dealers and carriers, street vendors and counter sales	0	0	G
2. Mail subscriptions	1253	1363	
C. Total Paid Circulation	1253	1363	r
D. Free Distribution (including samples)			c

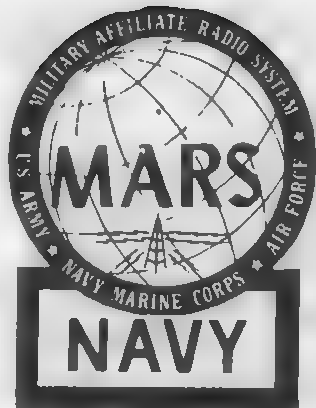

By Jim Wilson,  
W4GDK, NØWCK

If all of the 6th Naval District is getting as fine recruits

as  
it r  
F  
tac  
shi  
que  
by  
Na  
gr  
dri  
ust  
se  
fic  
,  
to  
tin  
nel  
the  
fri  
atc  
se:  
ce:  
ad  
loc  
l  
me  
co:  
tio:  
cor  
to  
ter  
the  
Wa  
;  
me  
RT  
as  
th

**"PROJECT ARGUS"**

(Continued from Page 1)

an engineer for TV Channel 4 of Miami, decided he was going to have a go at trying to make one of these units as a means of helping his several blind ham friends. Not being the kind of person who gives up easily, Don did not give up as various bugs showed up in the project. Late in '64 he had a unit which seemed ready for trial. Tho the eyes could not see the meter, his friend's ears told a very accurate story. Don's long effort had succeeded.

For awhile Don tried building these units one by one but he soon saw this would not work. On a hunch he contacted Broward Amateur Radio Club to seek their help. The upshot was that the club took it on as "Project Argus" with Don as an advisor. He has drawn up specific instructions for building them with helpful templates. Many members work on them in steps.

The first three units that Don Layman built were sponsored jointly by the County Cousins and the Florida SSB Assn. Two of these units went to the Fla. State School for the Blind WA4-TNG. The third one went to the school instructor, Joe Albrecht WA4EYY.

Win Hull WA4COR of West Palm Beach got the fourth one



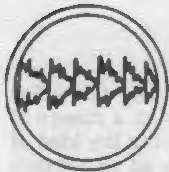

## The Florida Side Banders Association

By Bill Blasingame WA4NEV

Here it is time to write another column. These months are really flying by. I wonder how many of you have noticed that as you get older, time seems to pass much quicker.

I would like to say a hearty "Welcome Back" to W4MVB. It is nice to have you back down home. At the same time, I would like to take this opportunity on behalf of all Florida Side Banders to thank Tom Chisholm, W4FP for the wonderful job he did in the absence of the President.

On September 25th, W4HJL Don Blasdel, 12101 S.W. 188th St., Miami was certified as member #278. Don is married and has 2 3/4 harmonics. He formerly held the call K2QJE. Welcome Don, we're glad to have you with us.

We had only one program during September, but it was most enlightening and enjoyed by all. Mr. Chester Mathis, Director of the N.A.S.A. Radio and Telemetry Tracking Station at Ft. Myers, brought us up to date on the tracking of satellites both by

radio and telemetry. Mr. Mathis extended an invitation to all Side-Banders to visit the station any time they were in the area. I for one hope to visit with him the next time I get down that way.

It looks as though our Mobile Net may get started soon. The first check-in period will be Sunday November 13th from 0900 to 1000 E.S.T. There will be a base station to record the check-ins. Sure hope that all of those with mobile capacities will get on the air that morning. This is something we need very badly.

That about does it for this time. Hope to see all of you here next month. May the qrm get quiet and that bring lots of good DX-ing. 73-WA4NEV.

## VHF EASTERN FLORIDA

By Bertha Farr Eggert  
WA4-BMC

Still tracking Inez. What a strange hurricane.

Bev W4CKB, from Lake Placid, sent me a very interesting letter.

W5UGO, Okla. On Aug. 11 W1-MEH, Conn; on Aug. 11, W8-QOH, Ohio; on Aug. 12, K9UIF, Ind; on Aug. 12, K1BKK (vermont); on Aug. 13, W9BRN Ind; and on Aug. 13, W2AZL N.J. his #22 state. This is all on two meters! Almost nightly he works W4LSQ (144,100) Alabama, and W4VHH (144,086) S.C. 8:45 to 9:00 PM EST. He is looking for skeds. The first station in each new state worked via meteor scatter receives a free box of tree-ripened citrus fruit prepaid from the W4-CKB orange groves. This is wonderful news, Bev, and best of luck to you.

Al and Zelma, WA4FZV/WA-4MKE, write that the Dade County QSO party was a big success. They are still working on their RTTY for 2 meters.

The Palm Beach County 2 meter ARPSC net is doing a booming business. Check-ins range from Miami to Clearwater, and has an average of 20 to 30 stations participating. Look for this net on Wednesday nights, 8:30 PM EST on 145.350.

The Martin County net meets Monday nights at 8 PM, EST, on the same frequency. K4GZ or WA4IHH, are often the net controls.

Broward County net meets Monday nights, 8 PM, EST, on 145.230.

Two meters is quite active most any night. It's a nice friendly band and you will find many new and congenial friends.

Let me hear from all you VHF people, so that I can spread your news via this article.

### Every Dog Has Its Day

The day is coming! The day that will make some amateurs happy and a goodly number sad. It could also include a few manufacturers too. I am talking about the day the FCC puts into rule form just what constitutes an acceptable amateur SSSC signal. I don't mean a SSB signal but a single sideband suppressed carrier signal—the signal we "think" we are now putting out!

Onyx

## South Miami ARC At Dadeland

The South Miami ARC (K4-MRC) set up a complete amateur station at the Dadeland shopping center during Dade County amateur week. The Coral Gables Times sent a reporter down and did a story on the public service the club was doing. He learned we needed a meeting place, wrote about it in his story. The result was we now have a classroom with shops, metal and wood in which to meet.

The classroom and shop #1 is located at Ponce De Leon Jr. High school off Highway 1 on Marine Street, Coral Gables. It is at the extreme east end of the building on Mareus Street on the north side of the campus.

We have memberships open and we welcome new and old amateurs as well as prospective amateurs. 73 Charles Lingo WA4RSX.

### A HAM

By Leo R. Scagliozzi, W4VLN  
To be a ham is quite a feat, To talk with folks you'd like to meet,

And if our tone be only chatter Tis' quite all right, it doesn't matter.

And tho' our rig be big or small That doesn't mean a thing at all. Because the pleasure still is there,

So all of us may have our share. We claim no genti to be For oft times we are deep at sea. But, mostly folks, we get along We're just a happy merry throng.

And may I say that I am proud, To be in here with this mighty crowd.

(ED. NOTE -- These lines were written more than a quarter-century ago and are still applicable today.)



Back to school for Regis Kramer, Jr., of Miami. This small buzzer-key set-up is doing the trick. OM, W4ILE says he hopes to have him on the QFN/Slow net soon. QFN/S meets Mon.-Wed.-Fri. on 3651kc at 7:30 PM. Learn how to handle traffic on c.w. Listen in or better QNT (check in).

(Photo by W4ILE)

## Your QSL Bureau

By AL Hamel K4SJH, Vice Dir. SEDIV

Last report - Grand total mailed - 9,441 envelopes.

635 envelopes mailed since then - Total now 10,076.

All M, N, O, Ps, K4Zs, WA-4Bs have been mailed during this period.

We have had visitors from Sarasota, W4 Ft. Lauderdale, (K4SJH) Atlanta and Nashville, all of whom helped by working in the bureau.

All the Qs will be mailed next. We have received a total of 80,000 cards as a result of the DX contest in addition to the regular 8,000 to 10,000 cards received each week. All are sorted and will be assembled line mailed. All envelopes are sorted and filed. We regret that we still have cards for hams who do not have envelopes on file, and we are forced to destroy them in order to handle the load for those who do have envelopes on file. Due to

the tremendous stacks on hand we may from time to time mail some letters out of sequence in order to make our work easier. We still are spending about 200 manhours per month in the Bureau.

(From The Tenn. HAM)

### Hints and Kinks

By K4UGC

If you have a good ohm meter and two decade boxes, that will switch in steps of one ohm, to a million -- you have a DIGITAL ADDING MACHINE, on your work bench. You can write in and read out totals as fast as you can switch the decade knobs, and read ohmmeter. It has built in automatic carry, and is accurate as the resistors and meter.

Two decades can add any length, column of numbers, in pairs of numbers, up to the total of the ohmmeter scale, such as a thousand megohm.

Subtracting can be done also by setting decade (a) to 9,999 then write in decade (b) the number to be subtracted 666. Decades (a) and (b) will be in series with the ohmmeter. The meter reads 10,665 move meter needle back to first number 9,999 with zero now, then short out decade (b). The answer will be on the meter 9,333. A digital type ohmmeter will add to your shop equipment skill.

This is one way to do sums and get a lot of practice with the ohmmeter at the same time. 73 Dick Fredrick, K4UGC, Miami.

### GRID LEAKS

Oscilloscopes, I have concluded, are like women. They are a convenience and a necessity but you should never make the mistake that you think you completely understand them.

Onyx

### NOTICE

If You Receive 2 Copies  
of SKIP

It is no mistake. Please  
Pass it on to a friend.

... Editor

## Dear Mabel-

We enjoyed the visit with you so much and the Chinch Bug Festival at the Orange Bowl. How about H.Q. Slopot getting chosen as King of the Chinch Bugs? He's famous, isn't he?

You know I was a little embarrassed when Homer started unloading all of that gear at your house. I suppose all hams like to trade stuff, but it made our visit seem so businesslike. Especially when he and Clyde started haggling about the prices. It was tactful of you to bring in the coffee then. It does seem that no matter what happens to hams, coffee helps. Maybe it drives them all to drink, but coffee is all that they can afford.

But to get back to Homer's gear, Mabel, have you ever noticed that when they swap equipment they always bring home something larger? And dustier? And if they have something they don't need they swap it for something else they don't need?

Then it turns out that the only print available costs five dollars and is written in German, or all of the screws and nuts are a funny size and turn the wrong way...and without five more screws the whole thing sways a little from side to side. Or the owner-before-last modified it so that nobody is sure exactly what it does besides smoke.

Sometimes it's large and grey obviously built to survive a direct hit, but the only clue to what it might be is a Navy number. This generally turns out to be definitely surplus but the print is Classified. Or John, over in Fort Pierce, has the little diagrams, so you take a trip to see John. This somehow ends up with your husband swapping that hunk of gear to John for something they are both sure is valuable and Freddy up in Jacksonville knows all about it.

So there you are. Ready for Freddy.

Love, Gladys

### All Welcome

The Indian River Amateur Radio Club, Inc. welcomes all amateurs to their meetings the second Monday and fourth Tuesday at the Today Newspaper Auditorium in Cocoa at 1930 EST sharp. The club frequencies are 3825 and 146.97. They meet on the above freqs Sunday mornings at 0900 EST. The club president is Tom Dingman, W4HCG. Drop in on 3825 some Sunday and say hello.

**don  
simcox**

& ASSOCIATES

ADVERTISING  
LAYOUT

COPY  
PREPARATION

CALL 821-8432  
801 W. 49TH ST. HIALEAH

# HAMBAR

This column is FREE to any licensed Radio Amateur who is a subscriber to Florida Skip. Limit 3 per year. Additional \$1.00 each. Non-subscribers and non-amateurs \$1.00 each up to 10 lines. All listings are cancelled each month. If your listing is not moved, it will be necessary to re-list the following month.

To Licensed Amateurs; Buy, Swap, Sell (non-commercial)—Free.

To Commercial Business; Classified, undisplayed—50¢ per line; Illustrative or General Display with border—\$3.50 min., \$80/page; Initial cost of cuts, additional. Cuts furnished, no charge. Deadline 10th of month.

An Advertising inch is measured 7/8" vertically on one column, i.e., 4 columns—40 column inches to a page. Rate card by column inch supplied upon request. FLORIDA SKIP, Advertising Department, P.O. Box 501, Miami Springs, Fla.

FOR SALE: NAVY TCK-7 transmitter approx 700 watts with xtal calibrator. Continuous tuning from 2 thru 18 MHz, manual included. 3000 watt power supply. BC-348 free. \$200.00 Ken Fisher K4ZQI, 2110 NW 124th St., Miami, Fla. 33167. Phone 681-6782.

FOR SALE: Eico 753 transceiver and a.c. supply. Tri-band, 250 watts input. Looks clean, sounds better. Need money for college. \$225.00. John Deegan WA4QLZ, USF Box 412, Tampa 33520. Phone (813) 988-4131 Ext. 2317 or 2318.

FOR SALE: Under \$100.00. Elmac transmitter AF-67, PMR-7 receiver, PE103 d.c. power supply for AF-67, d.c. supply for receiver, 160 to 10 meters also covers BC band. Equipment still installed in car will demonstrate. Ralph Venegas K4WH/W2WH, 3421 SW 16th Ct., Ft. Lauderdale, Fla. 33312.

Even if you are on the right track, you'll get run over if you just sit there.

FOR SALE: NOVA TECH Pilot II 4 band portable aircraft receiver and DF including ac adapter. Brand new in carton with all accessories. Cost \$139.00, sell \$95.00. Eico Mod. 666 Dynamic conductance tube and transistor tester like new. Best offer. Hy -Gain TG-4 Tri-Band beam \$50. Saul Cohen K4ACJ, 4524 Michigan Ave., Miami Beach, Fla. JE 1-9782.

FOR SALE: NC-300 revr \$150. NC-300 converter (1-1/4, 2 and 6 meters) \$45.00. NC-300 VFO (2 and 6) \$30.00. NC-300 speaker in cabinet \$10.00. Ameco TX-62 transmitter \$120.00. Dow-Key DK-60-G2 \$10.00. Turner mike, mod. 254-C \$11.00. Filters for above all in mint or new condition. Package or terms. Arn Kogler WB4BJS, 3374 NW 33rd Ave., Ft. Lauderdale, Fla. 33309 phone 587-6238.

W4PJU ELECTRONIC TUBES, 504 E. Osceola Clewiston, Fla. 311A \$615, 813 \$22.00, 866A \$2.95, 61-46 \$2.95, 6146A \$3.95, 6146B \$4.85 6146W \$5.95, 4X150A \$14.50, 4X-150D \$16.50, 4X250B \$29.50, 8122 \$29.50. All prices plus tax and postage.

FOR SALE: Heath DX-60 and SX-24 \$100.00 Mike \$5.00. Heath battery eliminator BE-5 \$15.00. MG set 12 VDC in and 500 VDC at 200 ma. output. \$5.00. Vibrator supply 6 VDC or 110 VAC input, 400 VDC output 80 watts. \$5.00. VHF Nova-Tech model 710-WN tunes 108 to 130 MHz. \$15.00. Howard Ellison K4RFL, 38 Patrick Ct. Melbourne. Phone PA 3-2652.

Be careful of the theories on which you bias your opinions.

FOR SALE: "Original" Vibroplex bug \$12.00. D-104 mike EV-428 PTT base \$16.00. Hallcrafters R-47 speaker, 3.2 ohm \$7.00. Collins 3.1 kc mechanical filter No. F455J31 \$15.00. Mastercraft No. 7112 wall-desk 24 hour clock and 10 minute timer \$5.00. Cash postpaid. W. H. Kibbe W4CCD, 1575 Bellerose Dr. East, Clearwater, Fla. 33516.

FOR SALE: Gonset linear 101. Need H.V. transformer. Skylane Guad \$35.00. Cliff Dweller \$50.00. L.V. Moffitt W4UQJ, 2932 Forest Hill Blvd. W. Palm Beach, Fl. 33406. Phone 965-5515 or Miami 274-0154.

SACRIFICE: Complete station. Settle estate of the late Harry Eisen K4MYZ. HQ-180 \$225.00. HT-37 \$185.00. Autronic Keyer \$50.00. TR-44 Rotor \$35.00. AR-22 rotor \$15.00. SWR bridge \$20.00. Waters Coupler \$30. Eico VTVM \$15.00. 50 foot E-Z Way valvanized tower \$200.00. TA-33 beam \$50.00. Or entire station \$725.00. Excellent condition. Jean Eisen, 721 NE 170th St., North Miami Beach, Fla. 947-0870 after 6 P.M.

NOVICE CRYSTALS 80-40 Meters \$1.05 each. Also other freqs. Free list. Nat Stinnett W4AYV, Umatilla, Florida 32784.

URGENTLY NEED: C.W. station in Tallahassee, Pensacola, Jacksonville and Tampa to QNT (report in) on the State QFN c.w. net night at 2330 or 0300 GMT, 365 ltc. W4LUV, Mgr. QFN.

SELL COLLINS KWS-1 very clean, new 4CX250Bs \$575. Dick Ehrhorn W4ETO, 13315-108th Ave. North, Seminole, Fla. 33540 phone 813-595-3447 evenings (Clearwater).

FOR SALE: Hallcrafters HT-40 transmitter good condition \$60.00. W. Stuart WA4PCA, 1140 N.W. 77th Way, Hollywood, Fla. 33024. Phone 987-8845.

FOR SALE: CLEGG Thorn 6 with a.c. supply \$200.00. Heath Camache receiver \$40.00. Transverter 20 meter SSB to 6 meters - 4X150 final with rec. converter \$60.00. Bob Roberts WA4KSF, 4332 N.W. 2nd Street, Ft. Lauderdale, Fla. 33313

FOR SALE: RTTY REC-30 heavy duty TTY power d.c. supply \$5.00. Gonset 10-11 converter \$6.00 complete. New RG11U 5 cents a foot. QSTs IN binders for '44 '45 '46 and '47 \$5.00 each. HQ-180 speaker \$9.00. Heavy duty TV replacement transformers \$3.00 each. All FOB. Andy Clark W4IYT, 41 Lenape Dr., Miami Springs, Fla. 33166 888-3874.

FOR SALE: HQ-129X with speaker \$60.00. Stancor 1 kw. modulation transformer A-3899 \$25.00. D-104 mike with push to talk stand \$10.00. Speech amplifier and 304TH modulators, 700 watts of audio with tubes \$25.00 all excellent condition. Lou Littlefield, K4HEF, 1212 SW 18th St., Ft. Lauderdale, Fla. 33315.

WANTED: Instrograph, or equal, with tapes. Advise type, condition and price. Hal Williams W4YP, 9880 Caribbean Blvd., Perrine, Fla. 33157 238-2197 evenings.

SWAP OR SELL: Precision Mod. E400 sweep generator \$50.00. Precision Mod. 980 transistor-diode analyzer \$60.00. Eico Mod. 377 sign and square wave audio generator. Will swap for X Eico or Millen GDO (factory wired). Phico freq. meter BC-221-AE, 125 to 20,000 kcs with a.c. supply. \$75.00. Will swap above for ham gear. What have you? Victor Lindsay WN4DNP, Box 591, Port Salerno, Fla. 33492 Phone 287-4351.

FOR SALE: Unused surplus 3BP1s \$4.50. Transformer 1000-0-1000 v. Sec. 110 v. 60 cycle Pri. 230 ma. \$11.50 FOB. Ralph Coady W4BNI, 2903 Bay View Ave., Tampa, Fla. 33611.

FOR SALE: Elmac AF-67 transmitter, \$45.00 PS-2V a.c. supply for AF-67 \$25.00. B&W #426 75-ohm low pass filter (new, regularly \$22.75) \$15.00 or trade for B&W #425 50-ohm low pass filter. Knight grid-dip oscillator \$18.00. Webster band-spanner mobile whip with bumper mount \$10.00. What have you to trade? Ship collect, or deliver within 100 miles. George F. Reeves, Box 6, Williston, Fla. 32696 phone (904) 528-4761.

FOR SALE: OLD QSTs and CQs. 10 to 25 cents each. What you need? Teletype reper model 14, excellent condition \$30.00. 12 inch PM speaker unmounted \$3.50. Andy Clark W4IYT, 41 Lenape Dr., Miami Springs, Fla. 33166. Phone 888-3874.

FOR SALE: Ideal novice transmitter Viking Adventurer 50 watt all band c.w. mint clean \$35.00 with Heathkit VFO free bonus. RME preselector model DB-22A, good condition \$10.00. VHF signal generator LAF-3 80 to 600 mcs. AM, CW or Pulse. 110 volts a.c. input, giveaway at \$25.00. All FOB. M. G. Goldblatt W4EMB, 11801 SW 70th Ave., Miami, Fla. 666-6997 after 7 p.m.

FOR SALE: SWAN 250 plus a.c. 6 meters, brand new \$375.00 complete. 6 meter SSB-AM station including all band triple conv. revr and all band xmtr. CW-20A deluxe 10 mtr VFO, P&H 600A, \$135.00. Johnson 6N2 Thunderbolt factory wired, new condx best offer. Heath ho-13 ham scan, wired by ampeg company, brand new \$65.00. Waters 334 dummy load - wattmeter brand new \$69.00. J. W. Gregory K4OCK, 6495 Killian Dr., Miami 33156 Phone MO 1-7576.

FOR SALE: Complete station. HT-33A, HT-33B (2 KW Linear), SX-115, TR-44, TH-4 Beam, 60 foot EZ tower, mike, key, patch, desk, scope plus many other units. All in excellent condition. \$1685.70. See full

listing and picture on page 9 of Sept. SKIP. Neal L. Bartley K4REC, 3195 NW 18th St., Miami, Fla. 444-6205 or 635-4791.

FOR SALE: DRAKE 2A with xtal calibrator, 2BQ speaker, completely factory reconditioned. Looks and works like new. \$175.00. Harry E. Cudney, Jr., W4AKNA, 1541 NE 11th St., Homestead, Fla. Phone 248-1712.

FOR SALE: Drake-2B and HT-37 with accessories for only \$325.00. James Mattison W4FNE, 2237 Blossom Terr., Orlando, Fla.

PARTS GALORE! You name it, I've probably got it, especially for high power linears and power supplies. Will sell or trade for non-ham gear such as household items or golf/tennis gear. Bill Reeder, W4OLV, 196-05 NW 8th Ct., Miami, Fla. 621-8034.

FOR SALE: Apache TX-1 \$90.00. SB-10 SSB adaptor \$40.00. Will sell separate. Bob Sweeney WA4JWV, 1555 SW 21st Terr., Ft. Lauderdale, Fla. 581-2065.

ALL MINT condition. Latest factory modifications DX-100 \$100.00. SB-10 \$75.00 SX-101 Mk 3 \$125.00. Also miscellaneous. Jim Dillman K4USK, 356 41st Ave. N., St. Petersburg, Fla.

FOR SALE: SX-117, 80 to 10 receiver like new. Hallcrafters HA-5 VFO with all crystals 80 to 10. Heath VF-1. Mike Borenstein WA4GBM, 940 NE 176th St., Miami, Fla. 947-2767.

FOR SALE: Eico-753 transceiver, 200 watts 20, 40, 80. 752 d.c. power supply, and H-B a.c. supply, hustler mobile antenna 20, 40 and 80 all for \$275.00. (XYL objects to mobile operation). NC-300 receiver 100 kc marker, National converters 6, 2 and 1-1/4 in cab. \$175.00. 3 element short beam - 10, 15 and 20. \$20.00. Heath 5 inch scope \$20.00. Eico TV-FM sweep gen. \$20.00. CE-10A SSB with VFO \$45.00. Russ Gillispie W4OLW, 6444 NW Miami Place, Miami, Fla. 33150 Phone 754.8540.

FOR SALE: NC-300 \$95.00. Solid state stereo half cost \$50.00. Gonset 6 meter 115 a.c. or 12 vdc \$65.00. Heath Kit twoer and dc supply \$35.00. Antenna arrays for 6, 2 and 3/4 meters \$10.00 each. QST bound 6 issues \$3.00 each 1949-1959, binding cost \$3.25 each. Alliance c-225 Ham Rotator \$20.00. Chancey Barnes K4DZP, 1280 W. 37th St., Rialeah, Fla. 33010. Phone 822-1393.

FOR SALE: Heathkit DX-35, VF-1 VFO and ext. plate modulator all for \$35.00. 160 meter command xmtr \$10.00. Earl Dennis K4TMM, 12410 NW 19th Ave., Miami. 685-1772.

A recent CQ article (Nov. 62) by Bob Heil on the construction of a 6 N 2 SSB heterodyne units a good bit. Work well, reasonable cost, good low power, 10 watts PEP, but careful of the tube pin numbers on schematic. They are in error.....Other than this the units go....



# RTTY IN FLORIDA

By Bob Street W4IET

3704 kcs is still an active RTTY spot every evening in Florida when the Florida Amateur TeleType Net (FATT) meets at 0000Z. (7 PM EST) Even during the high QRN and QRM months this summer, the net averages from three to five checkins every night. So wire that converter, tune that dial, turn that printer on, and join the gang. Any shift you desire as Rex, W4ZAG, NC can copy most any shift from 2/3 of a hertz nertz to 1500 cycles (max of 900 cycles don't forget).

FATT handled about 40 SET messages Saturday night from the Tampa area. Nice going over there. Also another new station on the net now from Tampa is Herman, WA4KKG. Herman's 500 watts really pounds in over here on the east-coast.

Rex W4ZAG received the free booklet that Frederick Electronics Corporation is publishing, "An Introduction to Amateur Radio teletype" by Irvin Hoff, K8DKC. Rex says it is a must for the RTTYer. K8DKC also wrote the article on the fine TT/L converter in QST last year. See page 169 October QST for information on the Free RTTY booklet.

Also of interest to RTTYers this month is the Sixth World Wide RTTY Sweepstakes, October 22-24. Rules and information may be obtained in the October QST or from RTTY, Inc., 372 Warren Way, Arcadia, California. Logs should be received by November 30, 1966. Good luck and 73's. C U tonite on 3704 KCS.



## AMERICAN CAPTURES HIGH ITALIAN AWARD

Italian Consul-General Dr. Alvaro Beltrani, Los Angeles (left) and Mario M. Gavini, Western Regional Manager for Alitalia Airlines (right) notifying Commander Ray E. Meyers, W6MLZ, USN (ret.) that he is the recipient of the 1966 Columbus Gold Medal for Humanitarian Services. Commander Meyers, a feature writer for the Los Angeles Herald Examiner was chosen by the International Institute of Communications in Genoa for his interest and dedication in assisting the handicapped in technical radio communications. Commander Meyers is the first American to receive the Columbus Gold Medal for Humanitarian Services; in 1964 Dr. William H. Pickering of Jetpropulsion Laboratories in Pasadena, California was awarded the Gold Medal for Technical Services.

Commander Meyers will travel to Italy via Alitalia where the Medal will be presented to him by the President of the Italian Republic.

## ARPSC NET TOTALS

NET	QNI	QTC	SESSIONS	AVG TFC
FAST	966	191	26	7.0
GATOR	262	167	30	5.6
WPTN				
FPTN	411	136	26	5.0
FMTN	459	311	26	17.6
TPTN	532	182	26	7.0
QFN	768	406	59	6.8
RATT	98	28	30	1.0
SATN	406	248	27	9.1

## TOP TWENTY TRAFFIC TAKERS

Each month we are happy to list the top 20 Florida traffic takers. We hope to see your call here next month.

For September 1966:

1. WA4RQR BPL 639	11. W4BVE 121
2. WA4SCK BPL 623	12. W4LUV 116
3. WA4BMC BPL 311	13. WB4AIN 97
4. W4ILE BPL 295	14. W4SDR 90
5. WA4NEV 264	15. W4FP 78
6. W4FPC 198	16. K4BNE 77
7. WB4AJV 151	17. K4NMZ 67
8. WA4FGH 139	18. W4AKB 59
9. WA4EOQ 128	19. W4BSS 59
10. K4SJH 122	20. WA4IJH 58

16 FLORIDA SKIP, November 1966

## MY VISIT

(Continued from Page 1)

stacks are too large to hold anymore they are gone thru, matched up with the envelopes on file and placed in the mail. It is these stacks that I went thru to pick out my cards. I spent two hours working as hard as I could and brought back 96 cards for myself, 82 cards for W4YDD and 141 cards for W4AWIP.

There is another large table where the QSL cards are stacked for those stations who do not have an envelope in the file. This table is getting so full that they will soon have to be thrown away. What a shame!

Every amateur should send a large envelope to the bureau and put at least 2 five cent stamps on it.

The two hours that I spent I was only able to go thru the W4W stack, the W4Y stack and the W4AW stack. I found that it is a lot of hard work just going thru these cards, and as I understand it the Frey Radio club is a relatively small club and they put in about 200 man hours each month working in the bureau. They welcome any help that anyone cares to give.

The bureau is normally open Tuesday and Thursday nights, so if you want to visit try to arrive in Chattanooga in the afternoon of one of these days.

I must say that they are one of the most friendly and cooperative groups of people that I have ever met. They certainly showed me every courtesy. My only regret is that I didn't take my camera and get pictures of this activity. 73, Larry.

PUT ZIP  
in  
your mail

Include  
ZIP CODE NUMBERS  
IN ALL ADDRESSES



HAVE YOU JOINED THE



IF NOT, CONTACT YOUR

EMERGENCY COORDINATOR TODAY